

# INSTRUCTION MANUAL

## Orion Mini 50mm Guide Scope #8891

### Français

❶ Pour obtenir le manuel d'utilisation complet, veuillez vous rendre sur le site Web [OrionTelescopes.eu/fr](http://OrionTelescopes.eu/fr) et saisir la référence du produit dans la barre de recherche.

Mon compte • Suivi de commande • Chat • Aide | Français EUR ▾  
Connexion ▶  
Entrez le mot clé ou le numéro du produit  Rechercher ▶

❷ Cliquez ensuite sur le lien du manuel d'utilisation du produit sur la page de description du produit.

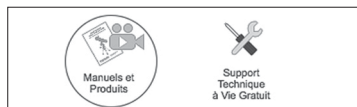

### Deutsche

❶ Wenn Sie das vollständige Handbuch einsehen möchten, wechseln Sie zu [OrionTelescopes.de](http://OrionTelescopes.de), und geben Sie in der Suchleiste die Artikelnummer der Orion-Kamera ein.

Mein Konto • Bestellstatus • Chat • Hilfe | Deutsch EUR ▾  
Anmelden ▶  
Geben Sie das Stichwort oder die Produktnummer ein.  Suchen ▶

❷ Klicken Sie anschließend auf der Seite mit den Produktdetails auf den Link des entsprechenden Produkthandbuchs.



### Español

❶ Para ver el manual completo, visite [OrionTelescopes.eu](http://OrionTelescopes.eu) y escriba el número de artículo del producto en la barra de búsqueda.

My Account • Order Status • Chat • Help | English EUR ▾  
Sign In ▶  
Enter keyword or product number  Search ▶

❷ A continuación, haga clic en el enlace al manual del producto de la página de detalle del producto.

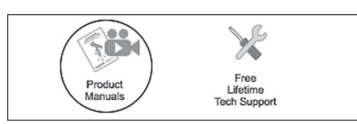

 **ORION**<sup>®</sup>  
**TELESCOPES & BINOCULARS**  
AN EMPLOYEE-OWNED COMPANY

Corporate Offices: 89 Hangar Way,  
Watsonville CA 95076 - USA  
Toll Free USA & Canada: (800) 447-1001  
International: +1(831) 763-7000  
Customer Support: [support@telescope.com](mailto:support@telescope.com)

Copyright © 2020 Orion Telescopes & Binoculars.  
All Rights Reserved. No part of this product instruction or any of its contents may be reproduced, copied, modified or adapted, without the prior written consent of Orion Telescopes & Binoculars.

Congratulations on your purchase of the Orion Mini 50mm Guide Scope – a “new breed” of simple, compact, and light-weight guide scope designed for use with the Orion StarShoot AutoGuider, Orion StarShoot Planetary Imager & AutoGuider, or similar, sensitive small-chip CCD cameras. It’s ideal for guiding long-exposure astrophotographs with short to medium focal length telescopes up to 1500mm focal length. Its bright, wide-field optics serve up lots of potential guide stars on your autoguider’s CCD sensor, and it’s small enough to stash in an accessory case!



**Figure 1.** The Mini 50mm Guide Scope and included components

---

## Parts List

- 1 Guide scope optical tube assembly
- 1 Dovetail bracket
- 1 Dovetail base
- 2 #8-32 x 3/8" flat (countersunk) Phillips head screws, and 2 hex nuts
- 2 #8-32 x 1/2" length flat (countersunk) Phillips head screws
- 1 Adapter plate
- 1 Socket head screw, 1/4"-20 x 1"
- 1 Socket head screw, 1/4"-20 x 1/2"
- 1 Parfocal ring, 1.25"
- 1 Allen wrench, 1.5mm

## Assembly

The Mini Guide Scope comes fully assembled and mounted in the dovetail bracket. Refer to **Figure 1** to familiarize yourself with the features and parts of the guide scope.

### Mounting the Mini Guide Scope

The Mini 50mm Guide Scope's mounting bracket has a dovetail foot that fits the Orion dovetail finder scope base included on many Orion telescopes. The guide scope also comes with a separate dovetail base (Orion part #7214), with two #8-32 x 3/8" flat Phillips-head screws and two hex nuts, for custom installations.

To mount the Mini 50mm Guide Scope on a dovetail plate such as Orion's Wide or Narrow Universal mounting plates, or similar plates produced under other brands, we've included an adapter plate that makes it easy. The Mini Guide Scope can then be piggybacked on top of your main instrument's tube rings, or on a side-by-side saddle plate, for autoguiding.

On the adapter plate there are three threaded holes. The two outer ones are for attaching the dovetail base to the adapter plate, using the two included #8-32 x 1/2" length flat (countersunk) Phillips head screws. (These are the longer of the four #8-32 screws.) Once the dovetail base is securely attached, you can mount the adapter plate onto a dovetail mounting bar or plate by inserting one of the supplied 1/4"-20 socket head screws up through an unthreaded hole or slot in the dovetail plate and into the 1/4"-20 hole in the center of the adapter plate. Tighten with a 3/16" Allen wrench (user supplied). We have provided two different socket head screws for your convenience, one is 1/2" long, the other 1" long. Choose the one that best fits your mounting bar or plate.

## Focusing

Focusing can be done in daylight on a distant object, or at night under the stars. For best results we recommend doing final, fine focusing at night at the beginning of your imaging session, following the focusing procedures in the imaging software you use for astrophotography, such as MaxIm DL, PHD Guiding, or Images Plus.

1. Slide the 1.25" parfocal ring onto the nosepiece of your autoguiding camera (**Figure 2**). If it doesn't slip on easily, make sure the three setscrews in the ring are backed off enough to provide clearance for the nosepiece. A 1.5mm Allen wrench is provided for adjusting the setscrews. Leave the ring loose on the nosepiece; do not tighten the setscrews yet.
2. Next, insert the nosepiece of your guide camera about halfway into the 1.25" holder of the guide scope, then *lightly* tighten the three thumbscrews on the holder to temporarily secure the autoguiding camera in place (**Figure 3**).
3. Make sure your autoguider camera is powered on and connected to your laptop computer, and that the software you will use for autoguiding is up and running. With the imaging software set to take continuous exposures, slightly loosen just one of the thumbscrews holding the autoguider nosepiece – just enough to be able to move it very gradually forward or back, while you watch the stars or reference numbers (e.g., FWHM) on your laptop screen. When the stars are pretty sharp, or you've reached approximately the lowest FWHM, tighten the loose thumbscrew so that the camera is secure in the guide scope.
4. Final, fine focusing can be done by rotating the objective lens cell on the front of the guide scope. First, back off the objective cell lock ring a couple of turns by rotating it counterclockwise (**Figure 4**). This frees up the objective cell to be turned either clockwise or counterclockwise. Turn it one way or the other by a quarter turn or so and see what effect that has on the star focus.

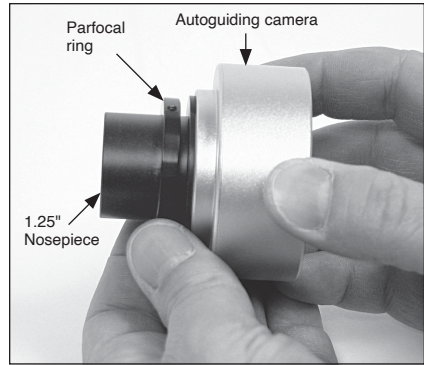

**Figure 2.** Slide the parfocal ring onto the 1.25" nosepiece of the Orion StarShoot AutoGuider or other autoguiding camera. Do not tighten the setscrews yet.

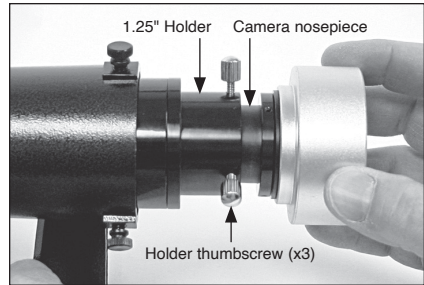

**Figure 3.** Insert the autoguider nosepiece about halfway into the 1.25" holder of the Mini Guide Scope, then lightly tighten the three thumbscrews on the holder to secure the camera in place for the moment.

Once you've achieved the best focus you can get, lightly re-tighten the lock ring by turning it clockwise while holding the objective lens cell steady. You're done!

Of course, if you turn the objective lens cell until it can rotate inward no further, or you rotate it outward so far that it unthreads completely and comes off, you should reset it to about the mid-point of its thread travel and re-adjust the coarse focus, i.e., the position of the autoguider nosepiece in the 1.25" holder. Then, you can attempt to fine-focus again using the objective lens cell.

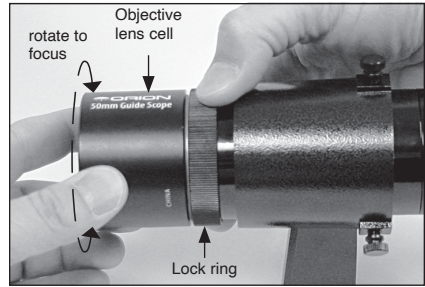
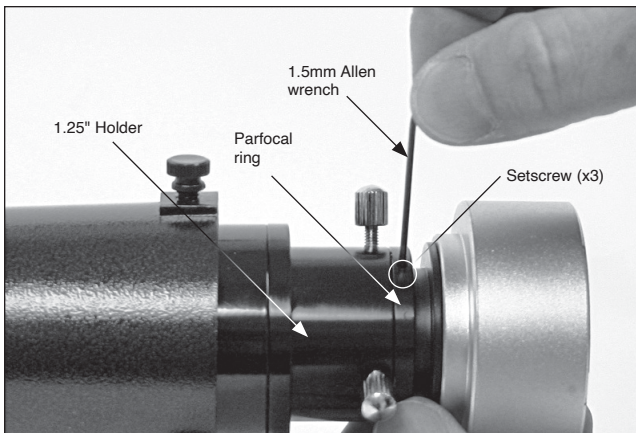

**Figure 4.** After setting the coarse focus with the camera in the guide scope holder, fine focusing can be done by rotating the scope's objective lens cell. First, you'll need to loosen the lock ring by rotating it counterclockwise a couple of turns.

### Setting the Parfocal Ring

Once the guiding camera's nosepiece has been set at the optimal focus position following the above procedure, you can lock the parfocal ring on the camera's nosepiece. This will enable you to return the camera to the same position in the guide scope's holder on subsequent imaging sessions (assuming you remove the camera from the guide scope after each session), obviating the need to go through the coarse focusing procedure (steps 2 and 3 above) again. You should still, of course check the guide scope's focus at each imaging session. But if any adjustment is needed, it will probably be minor and can be done using the fine focus of the objective lens cell (step 4 above).

To set the parfocal ring, which you inserted on the guide camera's nosepiece in step 1 above, simply slide it forward until it lies flush against the guide scope's 1.25" holder (**Figure 5**). Then carefully tighten each of the three setscrews in the ring.



**Figure 5.** Once focus is achieved, set the parfocal ring by first sliding it up against the 1.25" holder. Then, using the provided Allen wrench, secure the ring to the camera nosepiece with the three setscrews.

---

## Aiming the Mini Guide Scope

The Mini 50mm Guide Scope is mounted in a dovetail bracket that has three black thumbscrews to secure the guide scope tube in place. The tube is secured to the front of the bracket with a rubber O-ring. Although you may never need to do it in order to find a guide star, you can adjust the direction the guide scope is pointed within the bracket by alternately loosening and tightening the three thumbscrews. Just make sure that all three thumbscrews are tightened before you begin guiding. *Do not over-tighten them, however, or you could strip the screw threads.*

## Caring for the Mini 50mm Guide Scope

To keep dust from getting inside the guide scope and from accumulating on the objective lens, keep the front and rear caps installed when the guide scope is not in use. We recommend storing the guide scope in a padded accessory case.

### Cleaning the Lens

Although it shouldn't need cleaning very often, you can clean the front lens of the guide scope with any quality optical lens cleaning tissue and optical lens cleaning fluid designed for multi-coated optics. Never use regular glass cleaner or cleaning fluid designed for eyeglasses. Before cleaning with fluid and tissue, blow any loose particles off the lens with a blower bulb or compressed air. Then apply some cleaning fluid to a tissue, never directly on the optics. Wipe the lens gently in a circular motion, then remove any excess fluid with a fresh lens tissue. Oily fingerprints and smudges may be removed using this method. Use caution, as rubbing too hard may scratch the lens. Never re-use tissues.

### One-Year Limited Warranty

This Orion product is warranted against defects in materials or workmanship for a period of one year from the date of purchase. This warranty is for the benefit of the original retail purchaser only. During this warranty period Orion Telescopes & Binoculars will repair or replace, at Orion's option, any warranted instrument that proves to be defective, provided it is returned postage paid. Proof of purchase (such as a copy of the original receipt) is required. This warranty is only valid in the country of purchase.

This warranty does not apply if, in Orion's judgment, the instrument has been abused, mishandled, or modified, nor does it apply to normal wear and tear. This warranty gives you specific legal rights. It is not intended to remove or restrict your other legal rights under applicable local consumer law; your state or national statutory consumer rights governing the sale of consumer goods remain fully applicable.

For further warranty information, please visit [www.OrionTelescopes.com/warranty](http://www.OrionTelescopes.com/warranty).



**Corporate Offices:** 89 Hangar Way, Watsonville CA 95076 - USA  
**Toll Free USA & Canada:** (800) 447-1001  
**International:** +1(831) 763-7000  
**Customer Support:** [support@telescope.com](mailto:support@telescope.com)

*Copyright © 2020 Orion Telescopes & Binoculars. All Rights Reserved. No part of this product instruction or any of its contents may be reproduced, copied, modified or adapted, without the prior written consent of Orion Telescopes & Binoculars.*